

PRECAST CONCRETE

PADVULT - THREE-PHASE

4'-0" WIDE X 6'-0" LONG X 3'-8" TALL INSIDE DIMENSIONS

EQUAL TO PACIFICORP ZG 621

VCP ITEM #ZG621-PADVULT

SHEET 1 OF 5

PAD OPTIONS:

- TRANSFORMER PADS, SEE SHEET 2
- SECTIONALIZING CABINET PADS, SEE SHEETS 3, 4 & 5

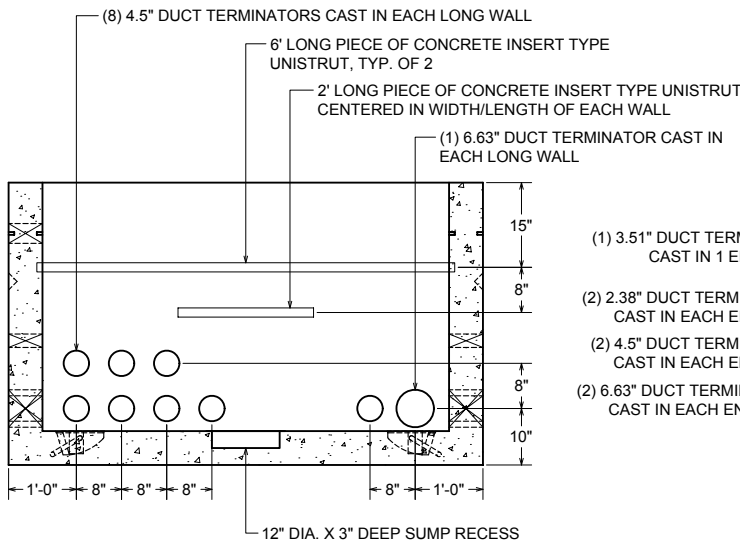
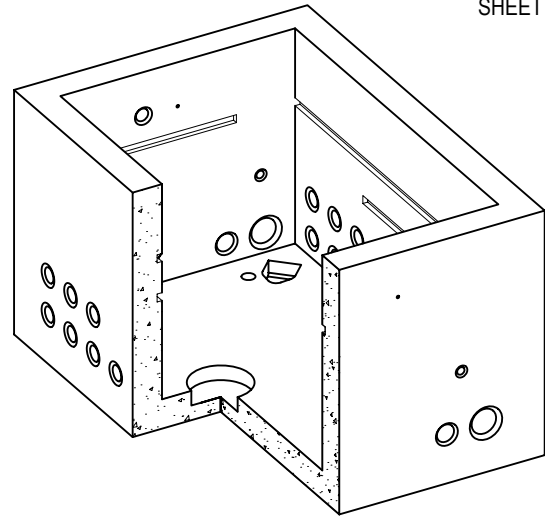
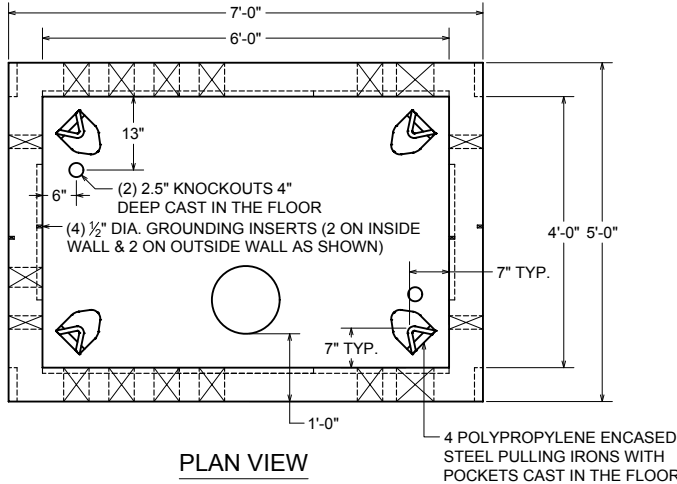

- (1) 3.51" DUCT TERMINATOR CAST IN 1 END WALL
- (2) 2.38" DUCT TERMINATORS CAST IN EACH END WALL
- (2) 4.5" DUCT TERMINATORS CAST IN EACH END WALL
- (2) 6.63" DUCT TERMINATORS CAST IN EACH END WALL

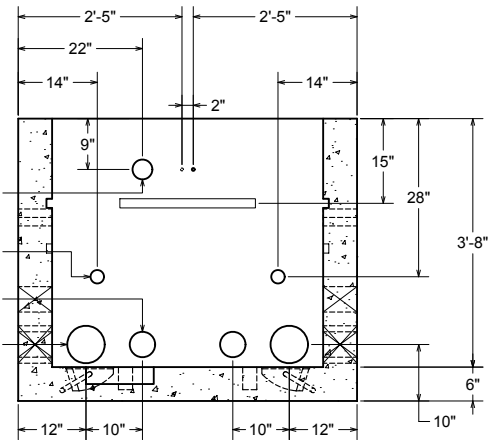

WEIGHT:

- VAULT WEIGHS APPX. 8,500 LBS.

LOADINGS:

- VAULT IS SUITABLE FOR AASHTO HS-20-44 TRAFFIC LOADINGS, PADS ARE NOT

NOTES:

- CONCRETE: 5000 P.S.I. MINIMUM
- REINFORCING: GRADE 60 MINIMUM REINFORCED WITH #4 @ 12" O.C.E.W.

ACTUAL DIMENSIONS OF CONCRETE PRODUCTS MAY VARY SLIGHTLY

LIFTING DETAILS:

VAULT TO LIFT FROM:

- (4) LIFT NOTCHES
- (4) PULLING IRONS IN THE FLOOR



DRAWING NOT TO SCALE

4X6 PADVULT.DWG
DATE CREATED: 10/10
UPDATED: 5/13

12650 Tucson Street • Henderson, Colorado 80640 • 303-659-3747, Fax 303-659-1333
2671 South Greeley Hwy • Cheyenne, Wyoming 82007 • 307-634-0695, Fax 307-634-0694
10021 Amarillo Blvd East • Amarillo, Texas 79108 • 806-374-3747, Fax 806-335-3717

www.vaughnconcreteproducts.com

PRECAST CONCRETE

TRANSFORMER PADVAULT PAD

84" OR 96" WIDE X 112" LONG X 8" THICK OVERALL DIMENSIONS

THREE-PHASE 75-750 KVA TRANSFORMER

EQUAL TO PACIFICORP ZG 521

VCP ITEM #ZG521-84 25KV PAD (SI# 7992600)

VCP ITEM #ZG521-96 35KV PAD (SI# 7992602)

SHEET 2 OF 5

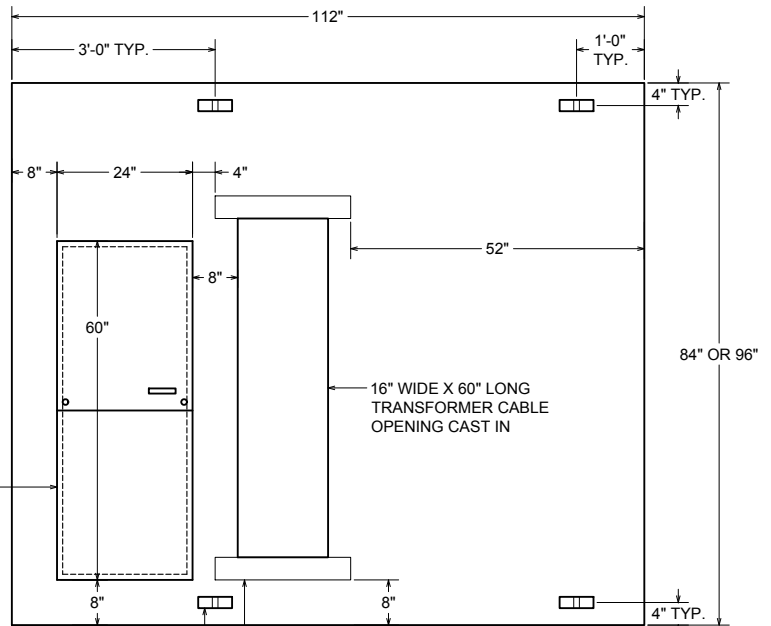
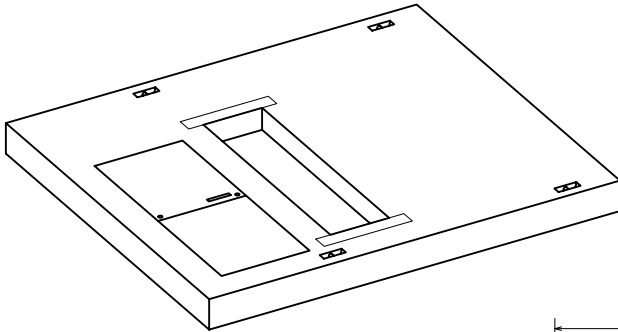

PLAN VIEW

ANGLE IRON FRAME WITH 2-LEAF 1/4" PLATE ACCESS DOOR ASSEMBLY CAST IN; FRAME & ACCESS DOORS ARE GALVANIZED; DOORS ARE SECURED WITH (2) 1/2" BOLTS OR PENTAHEAD BOLTS IF REQUESTED; DOORS ARE SUITABLE FOR INCIDENTAL 5,000 LB LOADS

4 SINK-ITS (RECESSED GALVANIZED LIFT BARS)

2"x4"x24" COMPOSITE BOARDS CAST IN PAD ON EACH END OF CABLE OPENING AS SHOWN, TYP. OF 2

ENTIRE TOP PERIMETER EDGE ROUNDED WITH CONCRETE EDGER



SECTION VIEW

LOADINGS:

- PADS ARE NOT SUITABLE FOR TRAFFIC LOADINGS, THEY ARE DESIGNED TO SUPPORT THE WEIGHT OF THE TRANSFORMER ONLY

NOTES:

- CONCRETE: 5000 P.S.I. MINIMUM
- REINFORCING: GRADE 60 MINIMUM REINFORCED WITH #4 @ 12" O.C.E.W.

ACTUAL DIMENSIONS OF CONCRETE PRODUCTS MAY VARY SLIGHTLY

LIFTING DETAILS

LIFT FROM 4 SINK-ITS (RECESSED GALVANIZED LIFT BARS)
ZG521-84 (25KV) PAD WEIGHT: 5,300 LBS.
ZG521-96 (35KV) PAD WEIGHT: 6,200 LBS.

DRAWING NOT TO SCALE

4X6 PADVAULT.DWG
DATE CREATED: 10/10
UPDATED: 5/13

vaughn concrete products, inc.

12650 Tucson Street • Henderson, Colorado 80640 • 303-659-3747, Fax 303-659-1333
2671 South Greeley Hwy • Cheyenne, Wyoming 82007 • 307-634-0695, Fax 307-634-0694
10021 Amarillo Blvd East • Amarillo, Texas 79108 • 806-374-3747, Fax 806-335-3717

www.vaughnconcreteproducts.com

PRECAST CONCRETE

SECTIONALIZING CABINET PAD

66" WIDE X 90" LONG X 6" THICK OVERALL DIMENSIONS

15kV THREE-PHASE SECTIONALIZING CABINET PAD

EQUAL TO PACIFICORP ZG 531-15kV

VCP ITEM #ZG531-15kV PAD (SI# 7992605)

SHEET 3 OF 5

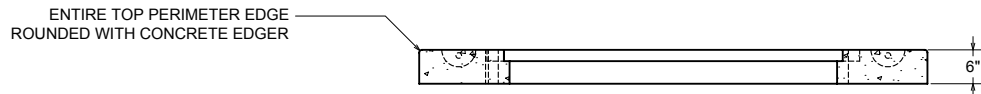
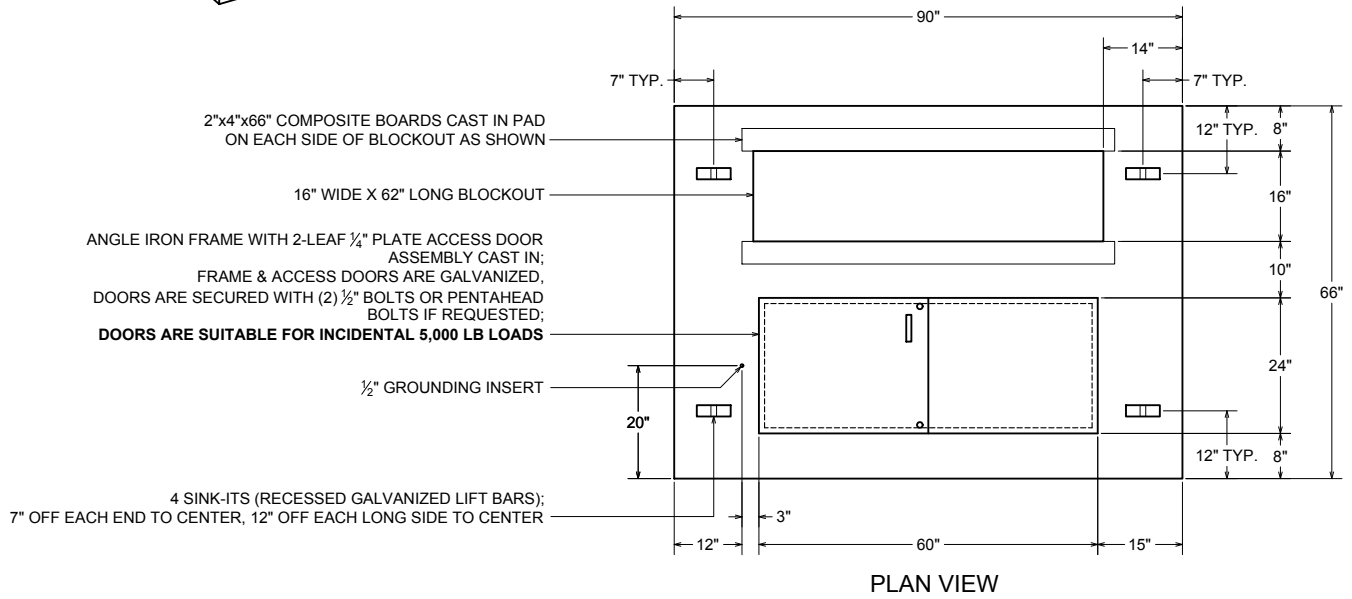
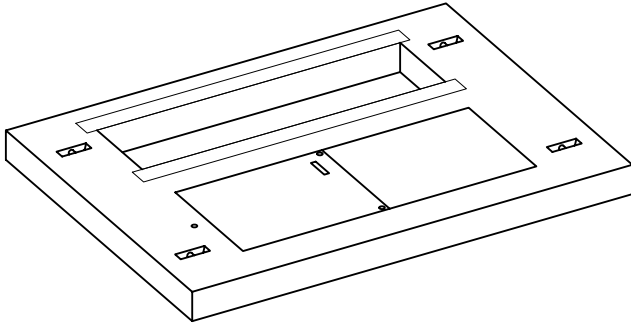

LOADINGS:

- PADS ARE NOT SUITABLE FOR TRAFFIC LOADINGS, THEY ARE DESIGNED TO SUPPORT THE WEIGHT OF THE TRANSFORMER ONLY

NOTES:

- CONCRETE: 5000 P.S.I. MINIMUM
- REINFORCING: GRADE 60 MINIMUM REINFORCED WITH #4 @ 12" O.C.E.W.

ACTUAL DIMENSIONS OF CONCRETE PRODUCTS MAY VARY SLIGHTLY

LIFTING DETAILS
 LIFT FROM 4 SINK-ITS
 (RECESSED GALVANIZED LIFT BARS)
 PAD WEIGHT: 2,200 LBS.

DRAWING NOT TO SCALE



4X6 PAD.VALL.T.DWG
 DATE CREATED: 10/10
 UPDATED: 5/13

12650 Tucson Street • Henderson, Colorado 80640 • 303-659-3747, Fax 303-659-1333
 2671 South Greeley Hwy • Cheyenne, Wyoming 82007 • 307-634-0695, Fax 307-634-0694
 10021 Amarillo Blvd East • Amarillo, Texas 79108 • 806-374-3747, Fax 806-335-3717

www.vaughnconcreteproducts.com

PRECAST CONCRETE

SECTIONALIZING CABINET PAD

66" WIDE X 94" LONG X 6" THICK OVERALL DIMENSIONS

25KV THREE-PHASE SECTIONALIZING CABINET PAD

EQUAL TO PACIFICORP ZG 531-25KV

VCP ITEM #ZG531-25KV PAD (SI# 7992606)

SHEET 4 OF 5

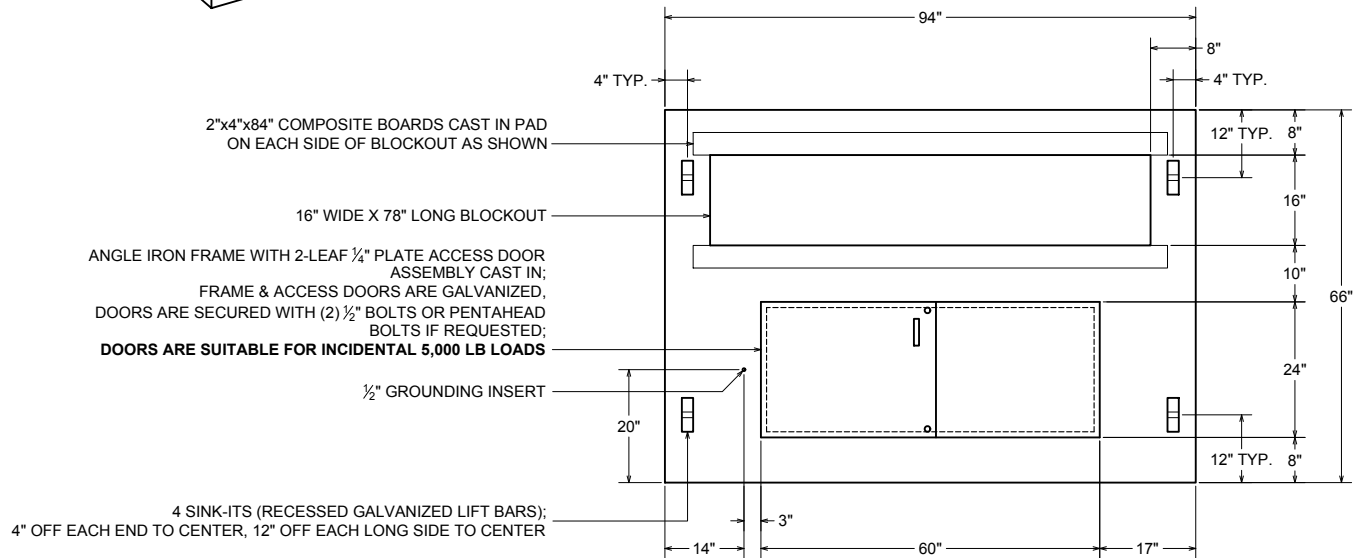
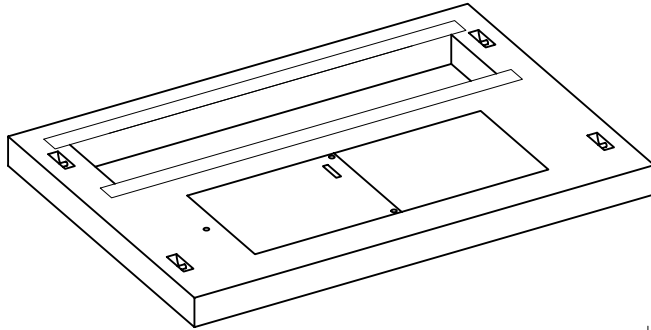

PLAN VIEW

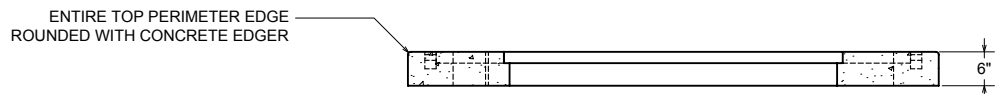

SECTION VIEW

LOADINGS:

- PADS ARE NOT SUITABLE FOR TRAFFIC LOADINGS, THEY ARE DESIGNED TO SUPPORT THE WEIGHT OF THE TRANSFORMER ONLY

NOTES:

- CONCRETE: 5000 P.S.I. MINIMUM
- REINFORCING: GRADE 60 MINIMUM REINFORCED WITH #4 @ 12" O.C.E.W.

ACTUAL DIMENSIONS OF CONCRETE PRODUCTS MAY VARY SLIGHTLY

LIFTING DETAILS
 LIFT FROM 4 SINK-ITS
 (RECESSED GALVANIZED LIFT BARS)
 PAD WEIGHT: 2,200 LBS.

DRAWING NOT TO SCALE

4X6 PADVALL.DWG
 DATE CREATED: 10/10
 UPDATED: 5/13



12650 Tucson Street • Henderson, Colorado 80640 • 303-659-3747, Fax 303-659-1333
 2671 South Greeley Hwy • Cheyenne, Wyoming 82007 • 307-634-0695, Fax 307-634-0694
 10021 Amarillo Blvd East • Amarillo, Texas 79108 • 806-374-3747, Fax 806-335-3717

www.vaughnconcreteproducts.com

PRECAST CONCRETE

SECTIONALIZING CABINET PAD

70" WIDE X 94" LONG X 6" THICK OVERALL DIMENSIONS

35KV THREE-PHASE SECTIONALIZING CABINET PAD

EQUAL TO PACIFICORP ZG 531-35KV

VCP ITEM #ZG531-35KV PAD (SI# 7992607)

SHEET 5 OF 5

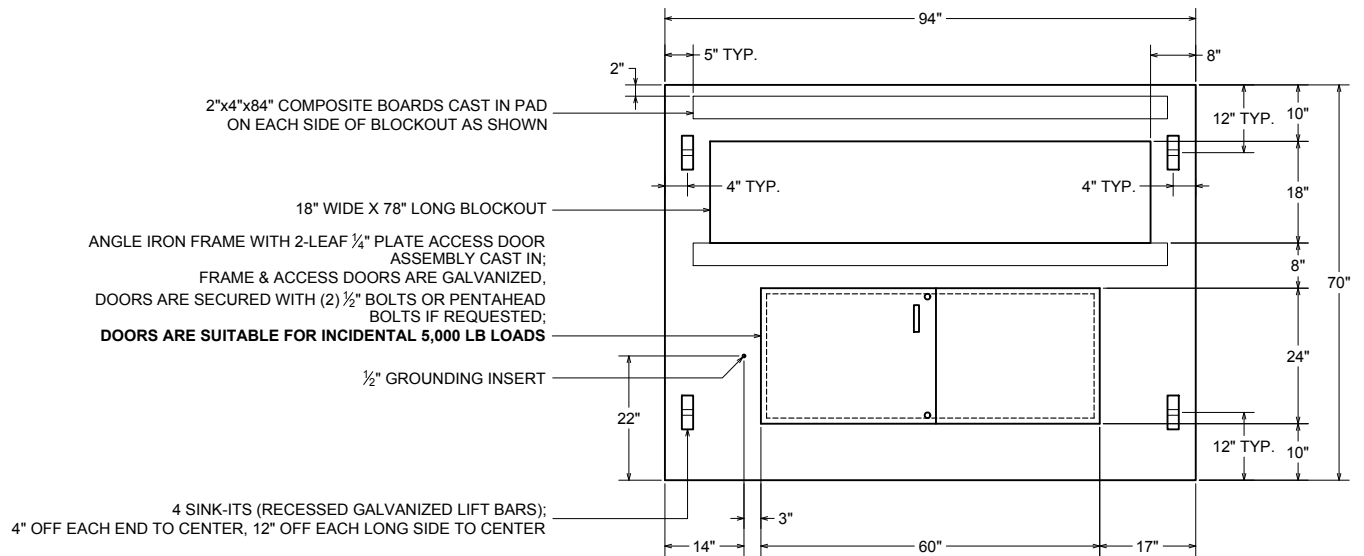
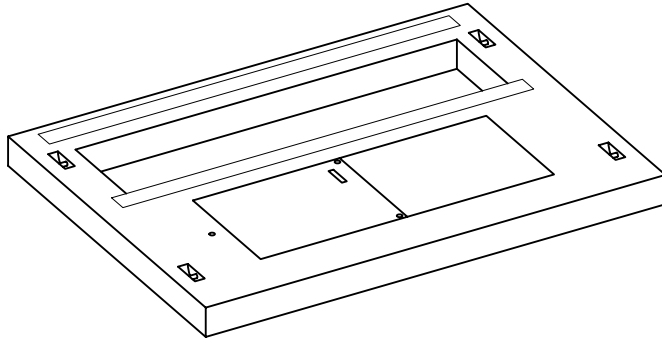

PLAN VIEW

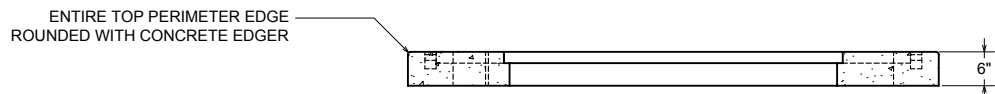

SECTION VIEW

LOADINGS:

- PADS ARE NOT SUITABLE FOR TRAFFIC LOADINGS, THEY ARE DESIGNED TO SUPPORT THE WEIGHT OF THE TRANSFORMER ONLY

NOTES:

- CONCRETE: 5000 P.S.I. MINIMUM
- REINFORCING: GRADE 60 MINIMUM REINFORCED WITH #4 @ 12" O.C.E.W.

ACTUAL DIMENSIONS OF CONCRETE PRODUCTS MAY VARY SLIGHTLY

LIFTING DETAILS

LIFT FROM 4 SINK-ITS
(RECESSED GALVANIZED LIFT BARS)
PAD WEIGHT: 2,200 LBS.

DRAWING NOT TO SCALE



4X6 PADVALL.DWG
DATE CREATED: 10/10
UPDATED: 5/13

12650 Tucson Street • Henderson, Colorado 80640 • 303-659-3747, Fax 303-659-1333
2671 South Greeley Hwy • Cheyenne, Wyoming 82007 • 307-634-0695, Fax 307-634-0694
10021 Amarillo Blvd East • Amarillo, Texas 79108 • 806-374-3747, Fax 806-335-3717

www.vaughnconcreteproducts.com