

ANGLE FRAME, PEDESTRIAN LOADING, DOUBLE DOOR - ALUMINUM

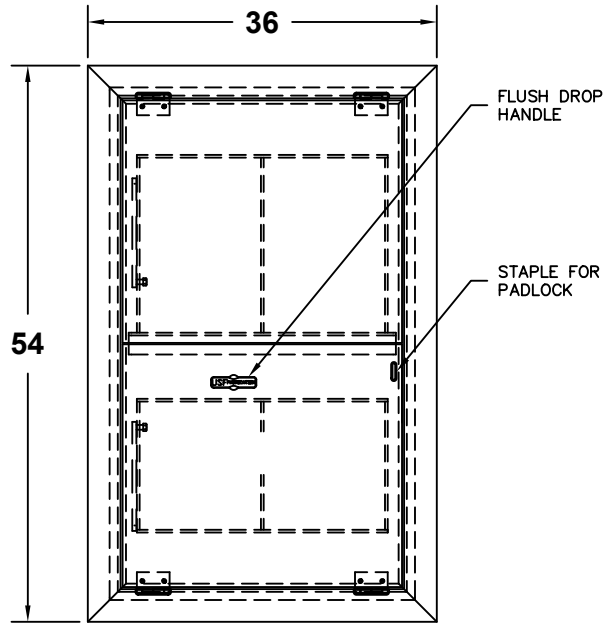

PLAN VIEW

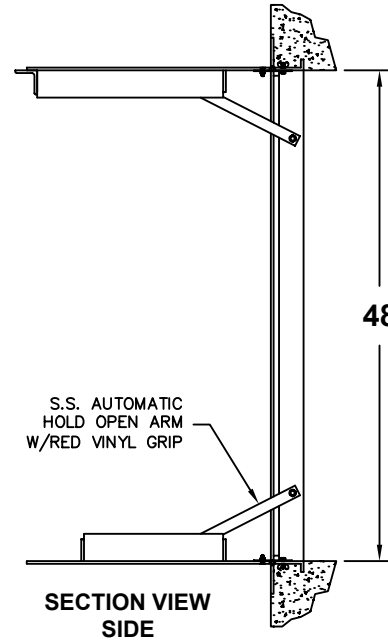

SECTION VIEW SIDE

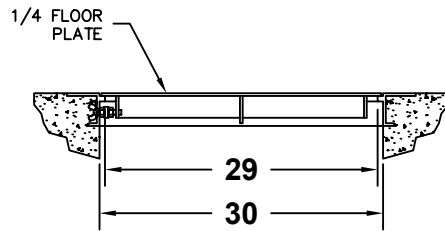

SECTION VIEW FRONT

NOTES:

Weight: 86 lbs. (approx. hatch base weight w/o options)

NOTES:

- 1- MATERIAL: ALUMINUM
- 2- LOADING: 300 LBS. PER SQ. FT.
- 3- 316 STAINLESS STEEL BOLTS HINGES AND HOLD OPEN ARM

U.S.F. FABRICATION INC.
FLOOR ACCESS DOORS, GRATING AND MISC. METAL FABRICATION



| | | |
|--------------------------|--------|-----------|
| APD300 30" x 48" | | |
| CLEAR OPENING: 29" x 44" | | |
| FROM: | QUOTE# | DATE: |
| WEB ID: 556 | 7408.2 | 11/4/2006 |