

PRECAST CONCRETE GREASE INTERCEPTOR

1000 GALLON CAPACITY
WITH LID FOR TRAFFIC
STANDARD FOR NEW MEXICO

IT IS THE EXCAVATOR'S OR
INSTALLER'S RESPONSIBILITY
TO REQUEST OUR
INSTALLATION GUIDELINES
PRIOR TO INSTALLING THIS
TANK

MONOLITHIC BODY NO SEAMS OR JOINTS

3" THICK FLOOR
4" THICK WALLS
8" THICK LID FOR TRAFFIC

2 COMPARTMENT TANK WITH
APPROXIMATELY 60% OF CAPACITY ON
INLET SIDE

TANK IS PROVIDED WITH NOTCHES IN
SIDEWALLS FOR SLIP-IN DIVIDER WALL

WITHSTANDS UP TO 6' OF BURY, RISERS
ARE AVAILABLE FOR INLET & OUTLET

OPTIONS:

- 24" I.D. MANHOLE RISERS
- GAS TIGHT CAST IRON RINGS & COVERS

INTERIOR UNDERSIDE OF LID & INTERIOR
WALLS OF THE TANK COATED WITH OUR
STANDARD BITUMINOUS COATING TO 6"
BELOW THE WATER LEVEL OF THE TANK

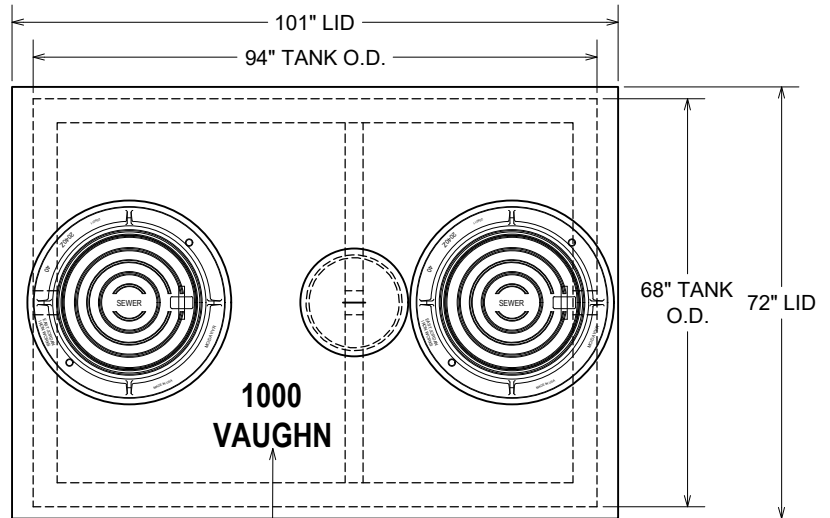

DURING PRODUCTION, "TANK SIZE" &
"VAUGHN" ARE STAMPED IN LID, "IN" &
"OUT" ARE MARKED ON TANK ENDS

PLAN VIEW

OUR STANDARD 24" DIAMETER CAST
IRON RINGS & COVERS, TYP. OF 2

24" I.D. MANHOLE RISER AS REQUIRED,
TYP. INLET/OUTLET END; AVAILABLE IN
2", 3", 4", 6", 8" & 12" HEIGHTS

CONSEAL JOINT SEALANT, OR
CONTRACTOR TO GROUT

PIPING BLOCKOUTS WITH POLYLOK
PIPE SEALS CAST IN TANK FOR INLET
& OUTLET PIPING (TYPICAL)

CONTRACTOR'S 4" PIPES

CONTRACTOR SUPPLIED
4" SDR35 INLET & OUTLET TEES

TANK WEIGHTS:

- TANK LID : 5,400 LBS.
- TANK WITH DIVIDER ONLY : 8,000 LBS.
- COMPLETE INTERCEPTOR : 13,400 LBS.

DIGGING SPECIFICATIONS:

- 54" BELOW THE INLET
- EXCAVATION: 7'-0" WIDE X 10'-0" LONG
- SEE OUR **INSTALLATION GUIDELINES**
PRIOR TO INSTALLING THIS TANK

CONCRETE : 4,000 P.S.I. (MINIMUM)
REINFORCING : REBAR & WELDED WIRE FABRIC

ACTUAL DIMENSIONS OF CONCRETE PRODUCTS MAY VARY SLIGHTLY

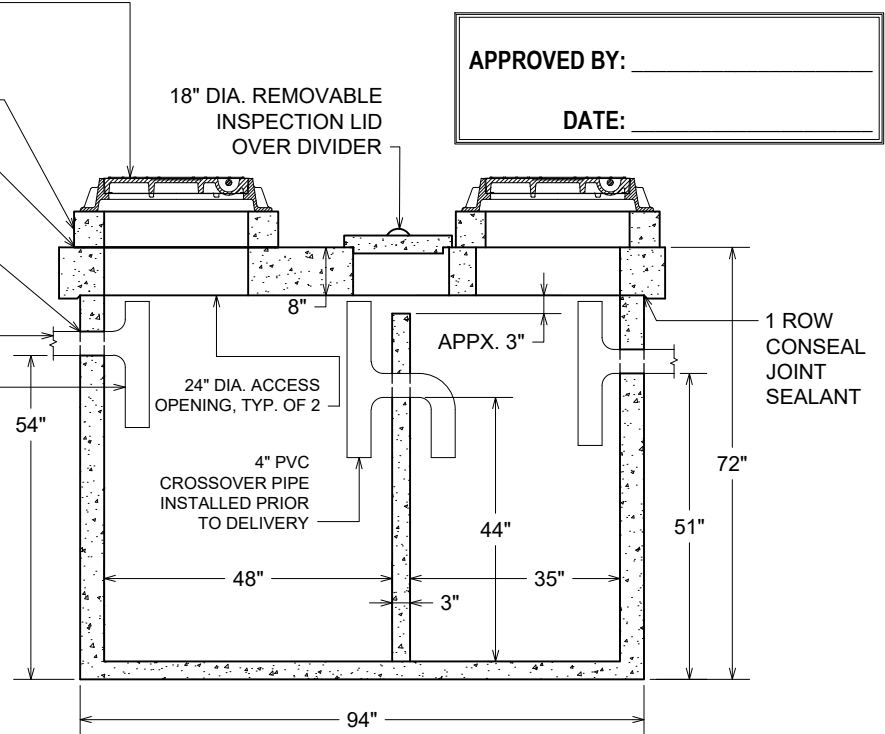

SECTION VIEW

APPROVED BY: _____

DATE: _____

DRAWING IS NOT TO SCALE

1000 GAL. GI, TRAFFIC-NM.DWG
DATE CREATED: 12/09
UPDATED: 8/2021

vaughn concrete products, inc.