

PRECAST CONCRETE

BOLLARDS

7½" DIAMETER X 7'-4" LONG

- GREAT FOR PROTECTING STORE FRONTS, GAS PUMPS, FENCING, GATES, SCHOOLS, TRANSFORMERS, SWITCH GEAR & UTILITIES OF ALL TYPES
- ROTO MOLDED POLYETHYLENE EXTERIOR SHELL FILLED WITH REINFORCED CONCRETE
- YELLOW BOLLARDS ARE IN STOCK & READY FOR PICK-UP
- RED, BLUE, GRANITE LIGHT GRAY OR GRANITE DARK GRAY BOLLARDS ARE AVAILABLE AS SPECIAL ORDER ITEMS (MIN. ORDER OF 20 REQUIRED)
- CONTRACTOR FRIENDLY
- EASY INSTALLATION
- IMPACT RESISTANT
- UV RESISTANT

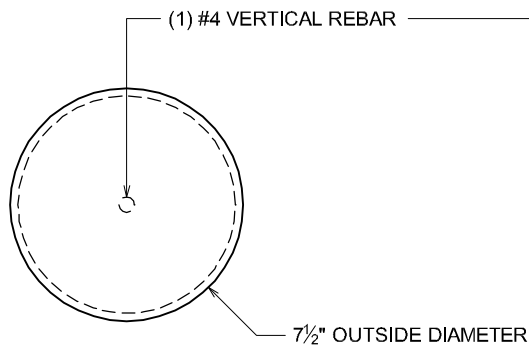

PLAN VIEW

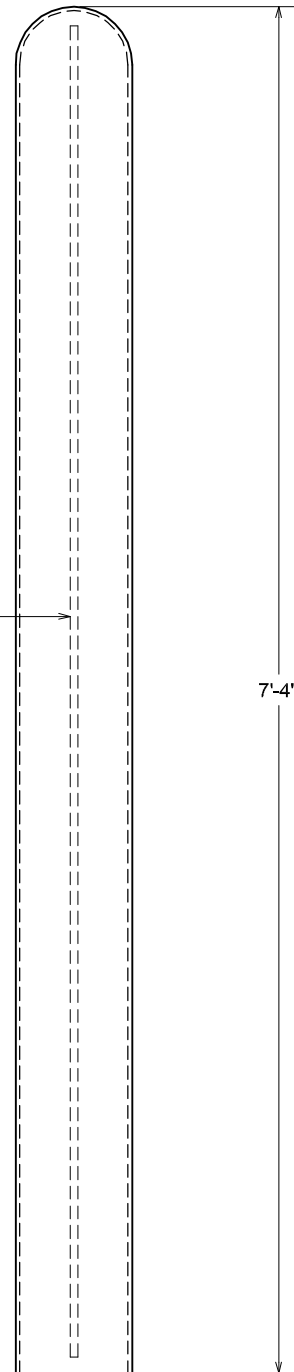

ELEVATION VIEW

WEIGHT:

- BOLLARD WEIGHS APPX. 335 LBS.

NOTES:

- CONCRETE: 4000 P.S.I. MINIMUM
- REINFORCING: (1) #4 VERTICAL REBAR

ACTUAL DIMENSIONS OF CONCRETE PRODUCTS MAY VARY SLIGHTLY

DRAWING NOT TO SCALE

vaughn
concrete products, inc.

7.5 INCH BOLLARD.DWG
DATE CREATED: 12/ 2009
UPDATE: -----

12650 Tucson Street • Henderson, Colorado 80640 • 303-659-3747, Fax 303-659-1333
2671 South Greeley Hwy • Cheyenne, Wyoming 82007 • 307-634-0695, Fax 307-634-0694
10021 Amarillo Blvd East • Amarillo, Texas 79108 • 806-374-3747, Fax 806-335-3717

www.vaughnconcreteproducts.com

Precast Concrete Bollards



vaughn **concrete products, inc.**

"Where Quality and Service Are Top Priority"

Keep the "things you value" safe!

- Bollards Are 7½" Diameter x 7'-4" Tall & Weigh Appx. 335 Lbs.
- Roto Molded Polyethylene Exterior, Filled With Reinforced Concrete
- Yellow Bollards Are In Stock & Available For Pick-Up
- The Following Colors Are Available As Special Order Items (Minimum Order Of 20 Required For These Colors)



- Impact Resistant
- UV Resistant
- Easy Installation
- Contractor Friendly
- Great For Protecting Utilities, Store Fronts, Gas Pumps, Fencing, Gates, Schools Or Anything That You Value!

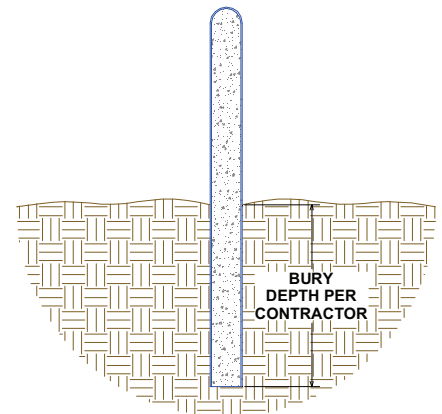

vaughn **concrete products, inc.**

12650 Tucson St – Henderson, CO
2671 So. Greeley Hwy – Cheyenne, WY
10021 Amarillo Blvd East – Amarillo, TX
Toll-Free Phone: (877) 827-8255
Toll-Free Fax: (877) 827-7363
www.vaughnconcreteproducts.com

Contact Us Today For Pricing & Availability!