

PRECAST CONCRETE CATCH BASIN

18" INSIDE DIAMETER
VCP ITEM #1515 ROUND CATCH BASIN

MANUFACTURED TO ASTM C-478

1/2" DEEP RECESSED KNOCKOUTS 9"
DIAMETER (MINIMUM) AT FLOOR LEVEL,
TYP. OF 2

1/2" STANDARD THREAD LIFTING
INSERTS CAST IN, TYP. OF 2

EXCAVATION TO BE PROPERLY
PREPARED WITH SUITABLE MATERIAL
TO PLACE STRUCTURE ONTO

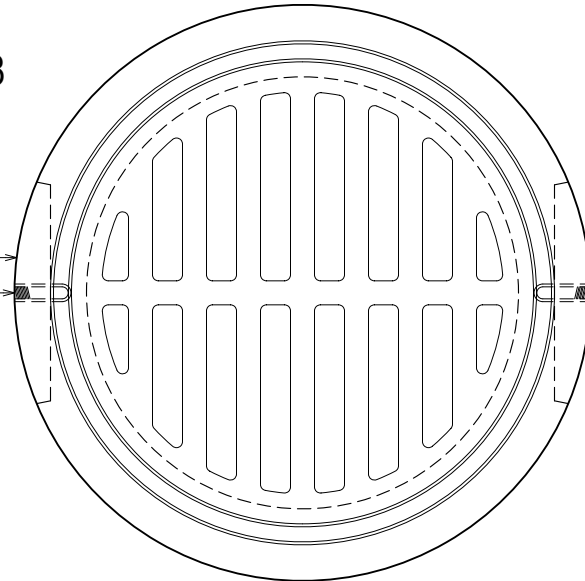

PLAN VIEW

OUR STANDARD CAST IRON RING & GRATE CAST IN
(OPEN FLOW AREA OF GRATE; 110 SQ. INCHES)

1/2" STANDARD THREAD LIFTING
INSERTS CAST IN, TYP. OF 2

1/2" DEEP RECESSED KNOCKOUTS 9"
DIAMETER (MINIMUM) AT FLOOR LEVEL,
TYP. OF 2

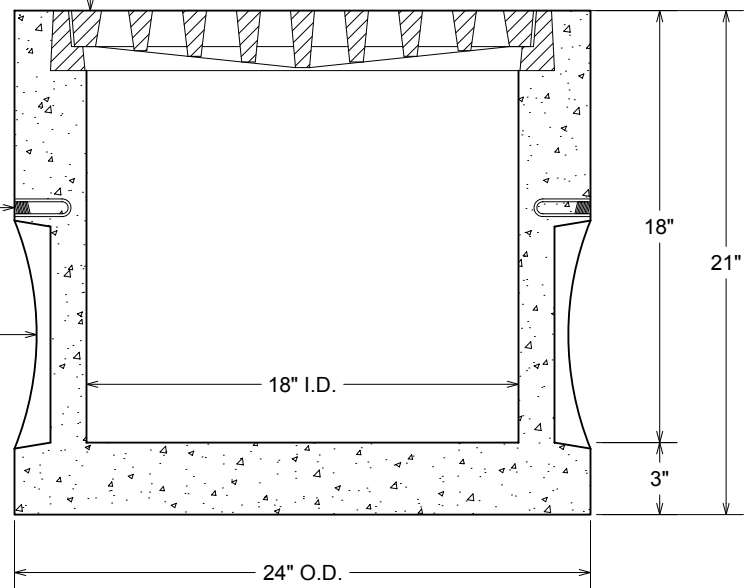

SECTION VIEW

WEIGHTS:

- COMPLETE CATCH BASIN WEIGHS APPX. 420 LBS.
- GRATE WEIGHS APPX. 70 LBS.

NOTES:

- CONCRETE: 4000 P.S.I. MINIMUM
- REINFORCING: GRADE 60 MINIMUM
- DESIGNED FOR AASHTO HS-20-44 LOADINGS WHEN PLACED ON MATERIAL CAPABLE OF SUPPORTING THE LOADINGS

ACTUAL DIMENSIONS OF CONCRETE PRODUCTS MAY VARY SLIGHTLY

**vaughn
concrete products, inc.**

DRAWING NOT TO SCALE

CATCH BASIN-18 DIAMETER.DWG
DATE CREATED: 12/06
UPDATED: 12/11

12650 Tucson Street • Henderson, Colorado 80640 • 303-659-3747, Fax 303-659-1333
2671 South Greeley Hwy • Cheyenne, Wyoming 82007 • 307-634-0695, Fax 307-634-0694
10021 Amarillo Blvd East • Amarillo, Texas 79108 • 806-374-3747, Fax 806-335-3717

www.vaughnconcreteproducts.com