

PRECAST CONCRETE CURB INLET - 24" ACCESS

2'-6" WIDE X 5'-0" OR 10'-0" LONG INSIDE DIMENSIONS

VCP ITEM #B-5 CURB INLET
VCP ITEM #B-10 CURB INLET

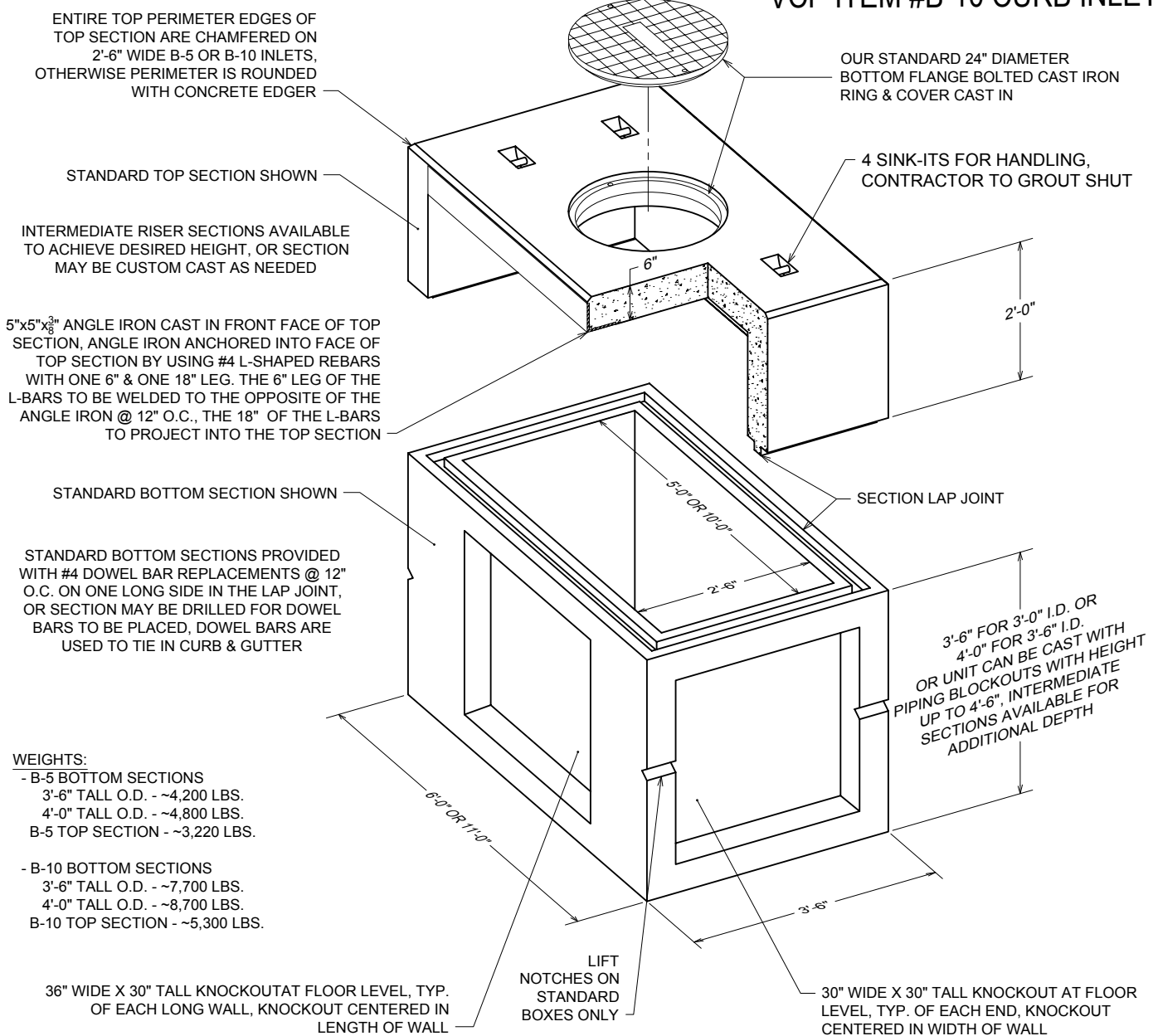

NOTES:

- CONCRETE: 5000 P.S.I. MINIMUM
- REINFORCING: GRADE 60 MINIMUM
- FLOOR, WALLS & ROOF ARE 6" THICK FOR BOTH BOX & TOP SECTION
- DESIGNED FOR AASHTO HS-20-44 LOADINGS

ACTUAL DIMENSIONS OF CONCRETE PRODUCTS MAY VARY SLIGHTLY

FOR LONGER CURB OPENING INSTALLATIONS, CUSTOM UNITS ARE AVAILABLE IN 15' & 20' INSIDE LENGTHS, OR USE MULTIPLE UNITS WITH FEEDER PIPES OR WINGS, SEE OTHER BROCHURES; CURB INLETS ALSO AVAILABLE AS SPECIAL ORDER ITEMS WITH AN INSIDE WIDTH OF 3'-6"

**vaughn
concrete products, inc.**

DRAWING NOT TO SCALE

2-6X5 OR 10 24-INCH CURB INLET - ISO.DWG
DATE CREATED: 11/05
UPDATED: 11/10

12650 Tucson Street • Henderson, Colorado 80640 • 303-659-3747, Fax 303-659-1333
2671 South Greeley Hwy • Cheyenne, Wyoming 82007 • 307-634-0695, Fax 307-634-0694
10021 Amarillo Blvd East • Amarillo, Texas 79108 • 806-374-3747, Fax 806-335-3717