

PRECAST CONCRETE PICNIC TABLE

PER WYDOT SPECIFICATIONS

ASSEMBLED TABLE WEIGHS APPX. 2,400 LBS.

SHEET 1 OF 4

ASSEMBLED
PLAN VIEW

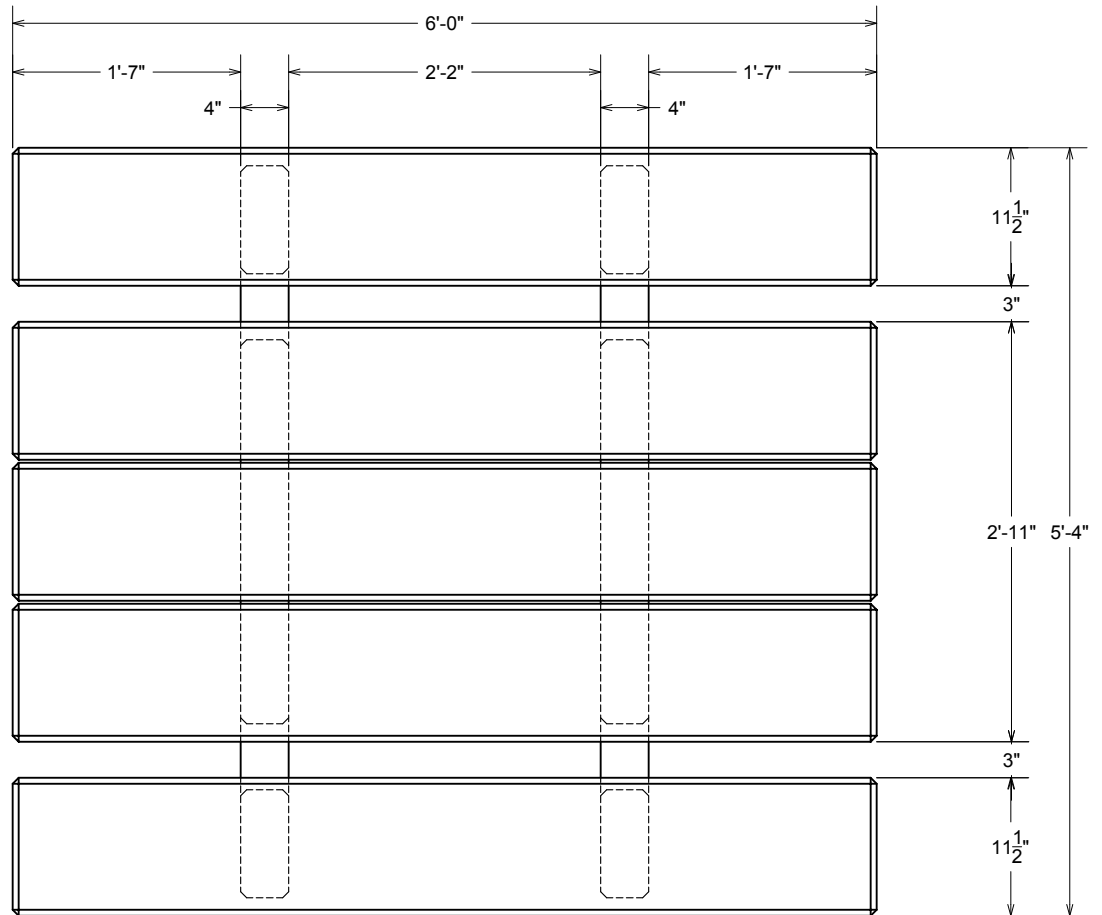

ASSEMBLED
SIDE VIEW

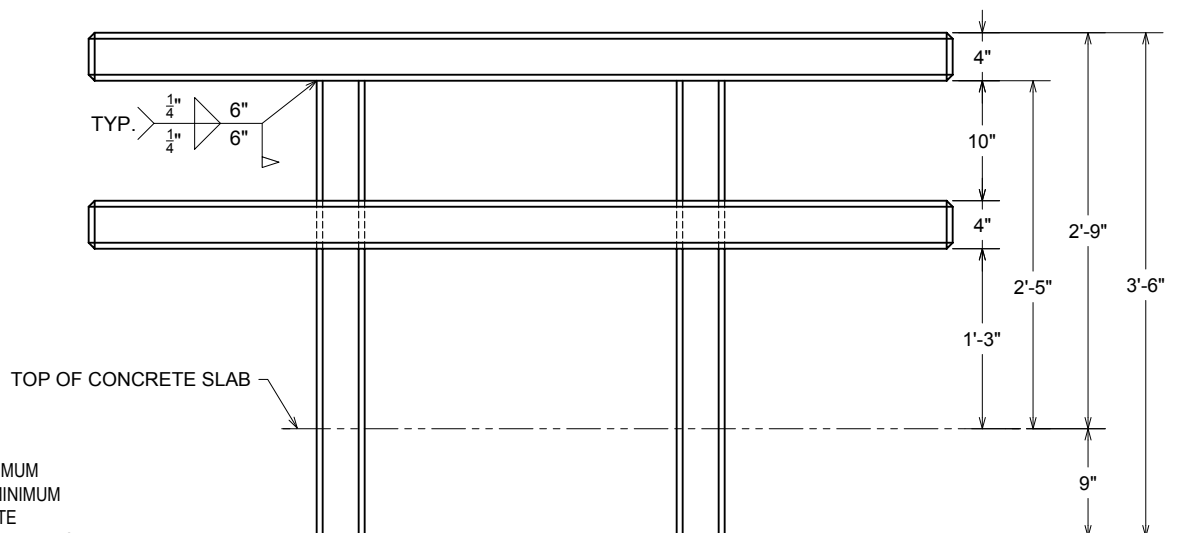

NOTES:

- CONCRETE: 4000 P.S.I. MINIMUM
- REINFORCING: GRADE 60 MINIMUM
- STANDARD GRAY CONCRETE
- STEEL FORM & STEEL TROWEL FINISH, TYP.
- SUPPLIED WITH GALVANIZED STEEL WELD PLATE CONNECTIONS UNDER TABLE FOR CONTRACTOR TO FIELD WELD & COLD GALVANIZE AFTER WELDING
- TABLE SUPPORTS TO BE REINFORCED w/ #4 REBAR $1\frac{1}{2}$ " FROM PERIMETER EDGES CENTERED IN 4" THICKNESS; EACH TABLE/BENCH SLAB REINFORCED w/ (4) #4 REBARS CENTERED IN 4" THICKNESS RUNNING LENGTH-WISE WITH $1\frac{1}{2}$ " COVER OFF SIDES AND ENDS; PROVIDE #4 REBARS @ 12" O.C. ON TOP OF (4) #4 REBARS THAT RUN THE LENGTH OF THE SLAB

ACTUAL DIMENSIONS OF CONCRETE PRODUCTS MAY VARY SLIGHTLY

PICNIC TABLE - WYDOT.DWG
DATE CREATED: 12/ 09
DATE MODIFIED: 5/ 13

DRAWING SCALE IS 1:16

**vaughn
concrete products, inc.**

2671 South Greeley Hwy Cheyenne, WY 82007-3681
Toll Free (877) 827-8255 Toll Free Fax (877) 827-7363
(307) 634-0695 Fax (307) 634-0694

PRECAST CONCRETE PICNIC TABLE

PER WYDOT SPECIFICATIONS

ASSEMBLED TABLE WEIGHS APPX. 2,400 LBS.

SHEET 2 OF 4

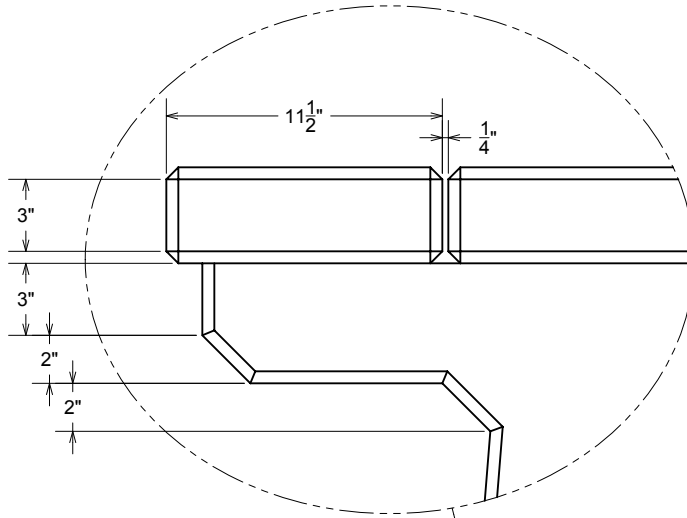

CONTRACTOR TO BEWARE TO PROPERLY PLACE THE HEIGHT OF THE TABLES PER PROJECT REQUIREMENTS;
29" MINIMUM FROM TOP OF SLAB TO UNDERSIDE OF TABLE;
34" MAXIMUM FROM TOP OF SLAB TO TOP OF TABLE

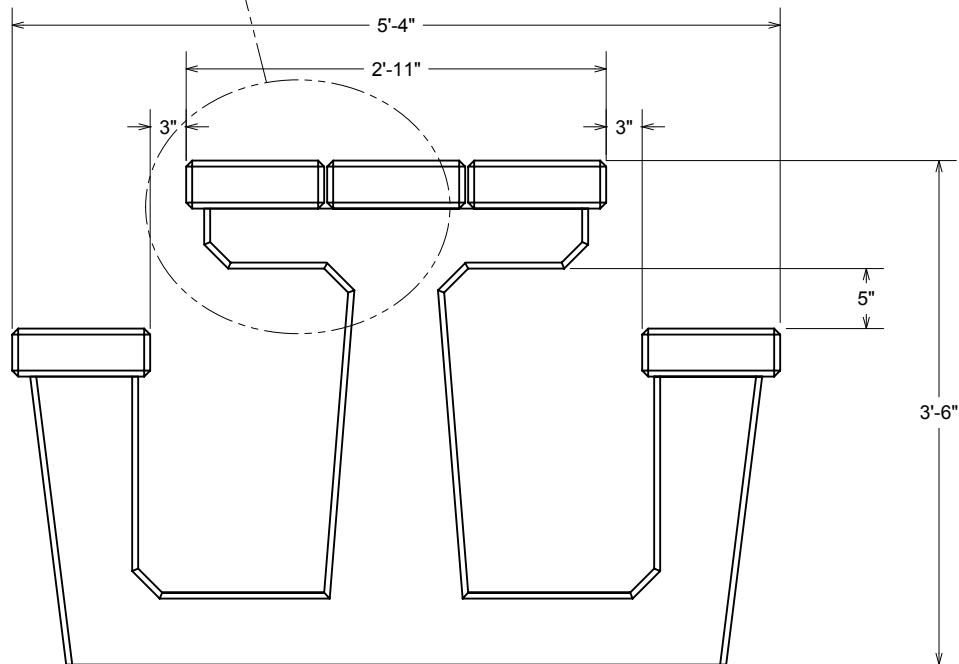

ASSEMBLED END VIEW

NOTES:

- CONCRETE: 4000 P.S.I. MINIMUM
- REINFORCING: GRADE 60 MINIMUM
- STANDARD GRAY CONCRETE
- STEEL FORM & STEEL TROWEL FINISH, TYP.
- SUPPLIED WITH GALVANIZED STEEL WELD PLATE CONNECTIONS UNDER TABLE FOR CONTRACTOR TO FIELD WELD & COLD GALVANIZE AFTER WELDING
- TABLE SUPPORTS TO BE REINFORCED w/ #4 REBAR 1 1/2" FROM PERIMETER EDGES CENTERED IN 4" THICKNESS; EACH TABLE/BENCH SLAB REINFORCED w/ (4) #4 REBARS CENTERED IN 4" THICKNESS RUNNING LENGTH-WISE WITH 1 1/2" COVER OFF SIDES AND ENDS; PROVIDE #4 REBARS @ 12" O.C. ON TOP OF (4) #4 REBARS THAT RUN THE LENGTH OF THE SLAB

ACTUAL DIMENSIONS OF CONCRETE PRODUCTS MAY VARY SLIGHTLY

PICNIC TABLE - WYDOT.DWG
DATE CREATED: 12/09
DATE MODIFIED: 5/13

DRAWING SCALE IS 1:16

vaughn
concrete products, inc.

2671 South Greeley Hwy Cheyenne, WY 82007-3681
Toll Free (877) 827-8255 Toll Free Fax (877) 827-7363
(307) 634-0695 Fax (307) 634-0694

PRECAST CONCRETE PICNIC TABLE

DETAIL OF PICNIC TABLE LEG
 2 REQUIRED FOR EACH TABLE
 SHEET 3 OF 4

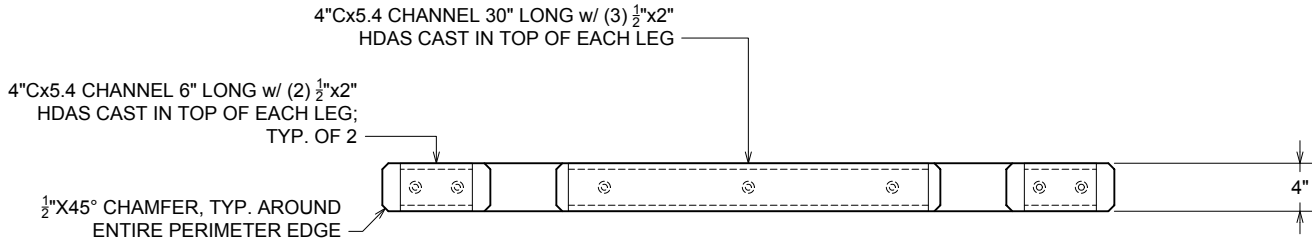

PLAN VIEW

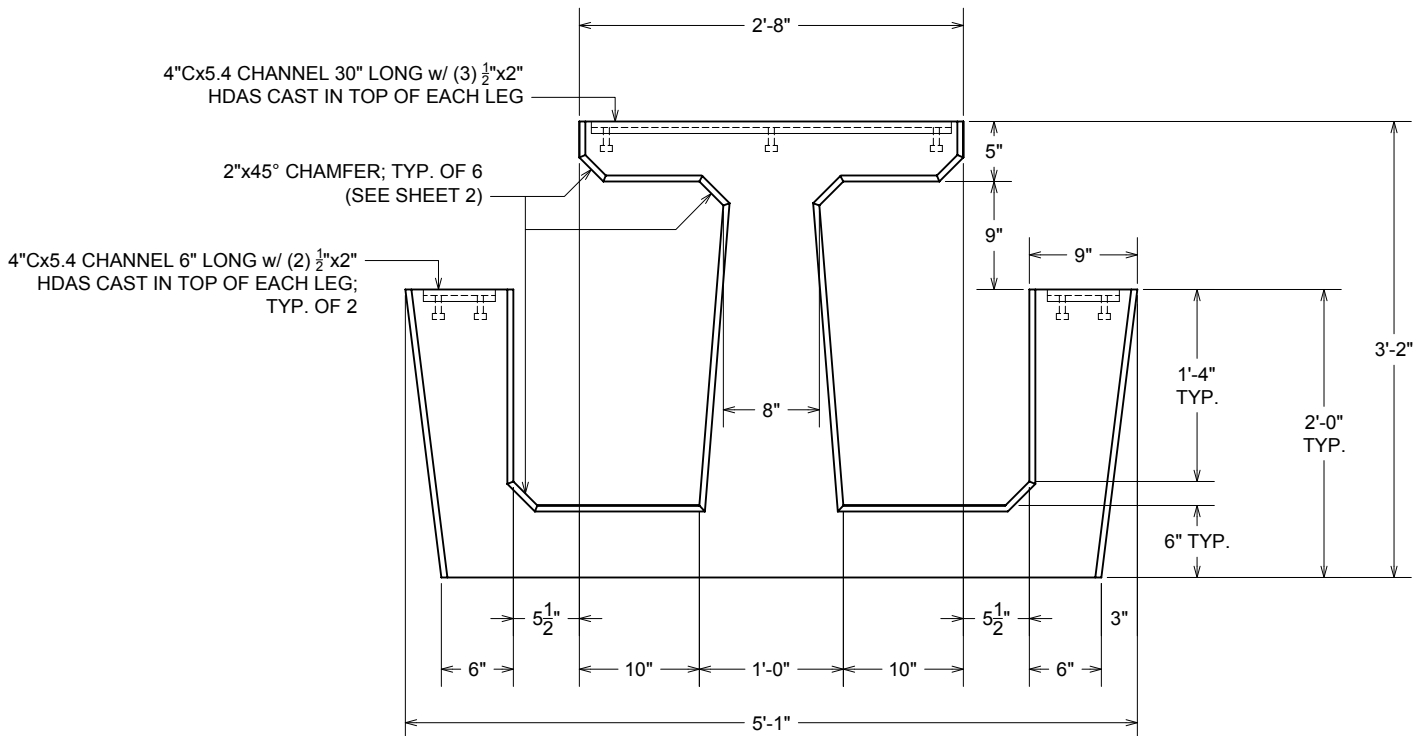

END VIEW

NOTES:

- CONCRETE: 4000 P.S.I. MINIMUM
- REINFORCING: GRADE 60 MINIMUM
- STANDARD GRAY CONCRETE
- STEEL FORM & STEEL TROWEL FINISH, TYP.
- SUPPLIED WITH GALVANIZED STEEL WELD PLATE CONNECTIONS UNDER TABLE FOR CONTRACTOR TO FIELD WELD & COLD GALVANIZE AFTER WELDING
- TABLE SUPPORTS TO BE REINFORCED w/ #4 REBAR 1 1/2" FROM PERIMETER EDGES CENTERED IN 4" THICKNESS; EACH TABLE/BENCH SLAB REINFORCED w/ (4) #4 REBARS CENTERED IN 4" THICKNESS RUNNING LENGTH-WISE WITH 1 1/2" COVER OFF SIDES AND ENDS; PROVIDE #4 REBARS @ 12" O.C. ON TOP OF (4) #4 REBARS THAT RUN THE LENGTH OF THE SLAB

ACTUAL DIMENSIONS OF CONCRETE PRODUCTS MAY VARY SLIGHTLY

PICNIC TABLE - WYDOT.DWG
 DATE CREATED: 12/09
 DATE MODIFIED: 5/13

DRAWING SCALE IS 1:16

vaughn
concrete products, inc.

2671 South Greeley Hwy Cheyenne, WY 82007-3681
 Toll Free (877) 827-8255 Toll Free Fax (877) 827-7363
 (307) 634-0695 Fax (307) 634-0694

PRECAST CONCRETE PICNIC TABLE

DETAIL OF PICNIC TABLE BENCH & TABLE SLAB

5 REQUIRED FOR EACH TABLE

SHEET 4 OF 4

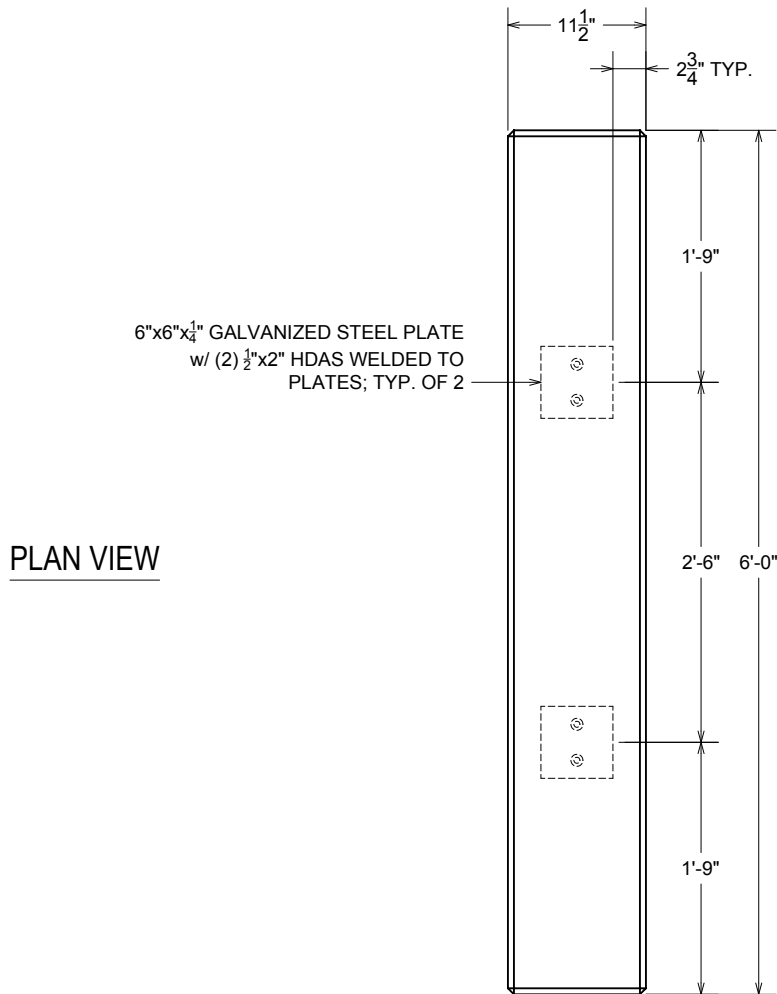

END VIEW

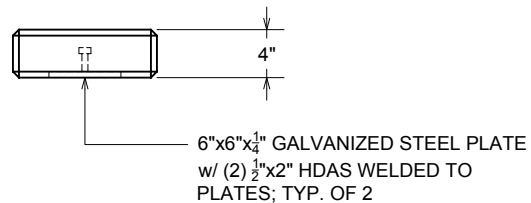

NOTES:

- CONCRETE: 4000 P.S.I. MINIMUM
- REINFORCING: GRADE 60 MINIMUM
- STANDARD GRAY CONCRETE
- STEEL FORM & STEEL TROWEL FINISH, TYP.
- SUPPLIED WITH GALVANIZED STEEL WELD PLATE CONNECTIONS UNDER TABLE FOR CONTRACTOR TO FIELD WELD & COLD GALVANIZE AFTER WELDING
- TABLE SUPPORTS TO BE REINFORCED w/ #4 REBAR 1 1/2" FROM PERIMETER EDGES CENTERED IN 4" THICKNESS; EACH TABLE/BENCH SLAB REINFORCED w/ (4) #4 REBARS CENTERED IN 4" THICKNESS RUNNING LENGTH-WISE WITH 1 1/2" COVER OFF SIDES AND ENDS; PROVIDE #4 REBARS @ 12" O.C. ON TOP OF (4) #4 REBARS THAT RUN THE LENGTH OF THE SLAB

ACTUAL DIMENSIONS OF CONCRETE PRODUCTS MAY VARY SLIGHTLY

PICNIC TABLE - WYDOT.DWG
DATE CREATED: 12/ 09
DATE MODIFIED: 5/ 13

DRAWING SCALE IS 1:16

vaughn
concrete products, inc.

2671 South Greeley Hwy Cheyenne, WY 82007-3681
Toll Free (877) 827-8255 Toll Free Fax (877) 827-7363
(307) 634-0695 Fax (307) 634-0694