

Precast Concrete

STORAGE SHED

10'-0" WIDE X 12'-0" LONG X 8'-7" HIGH INSIDE DIMENSIONS

FEATURES

SATISFIES ACI BUILDING CODES

DURABLE

CAN BE MOVED

WEATHER RESISTANT

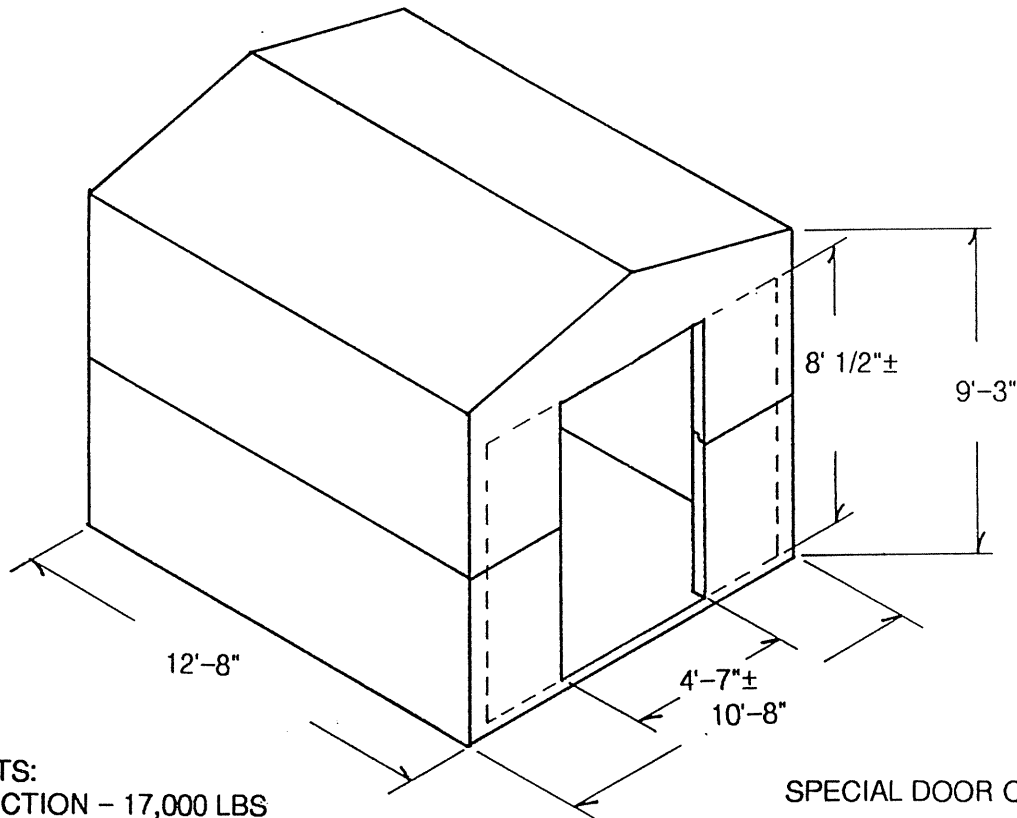

WEIGHTS:
TOP SECTION - 17,000 LBS
BOTTOM SECTION - 15,200 LBS

SPECIAL DOOR OPENINGS
AVAILABLE

REINFORCED CONCRETE 4000 PSI MINIMUM

Actual dimensions of concrete products may vary slightly

vaughn
concrete products, inc.

12650 Tucson Street • Henderson, Colorado 80640 • 303-659-3747, Fax 303-659-1333
2671 So. Greeley Hwy • Cheyenne, Wyoming 82007 • 307-634-0695, Fax 307-634-0694
10021 Amarillo Blvd. East • Amarillo, Texas 79107 • 806-374-3747, Fax 806-335-3717