

# PRECAST CONCRETE SAMPLING BASIN

18" I.D. X 17" HIGH INSIDE DIMENSIONS  
VCP ITEM #SAMPLING BASIN

**APPROXIMATE WEIGHTS:**

- BOTTOM BASIN SECTION: 260 LBS.
- LID W/ HDPE: 180 LBS.
- CAST IRON RING: 33 LBS.
- CAST IRON COVER: 34 LBS.

**PLAN VIEW**

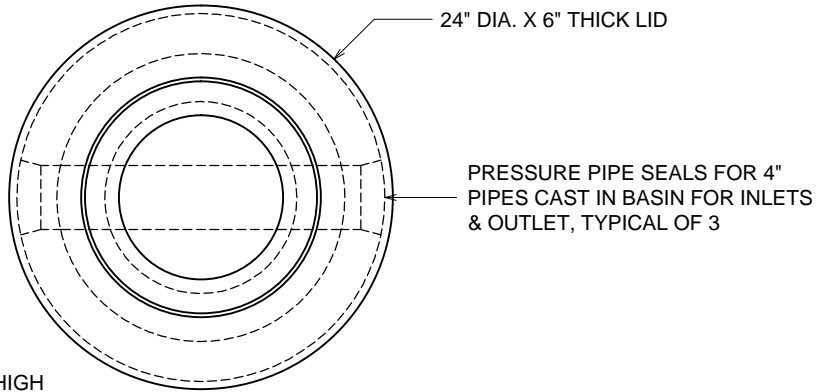

**\*\*FOR DEEPER APPLICATIONS THE 12" I.D. RIBBED HIGH DENSITY POLYETHYLENE RISER SECTION CAN BE PROVIDED WITH LENGTH AS REQUIRED & THE INLET CAN BE FIELD PLACED AND SEALED INTO THE 12" I.D. RISER SECTION\*\***

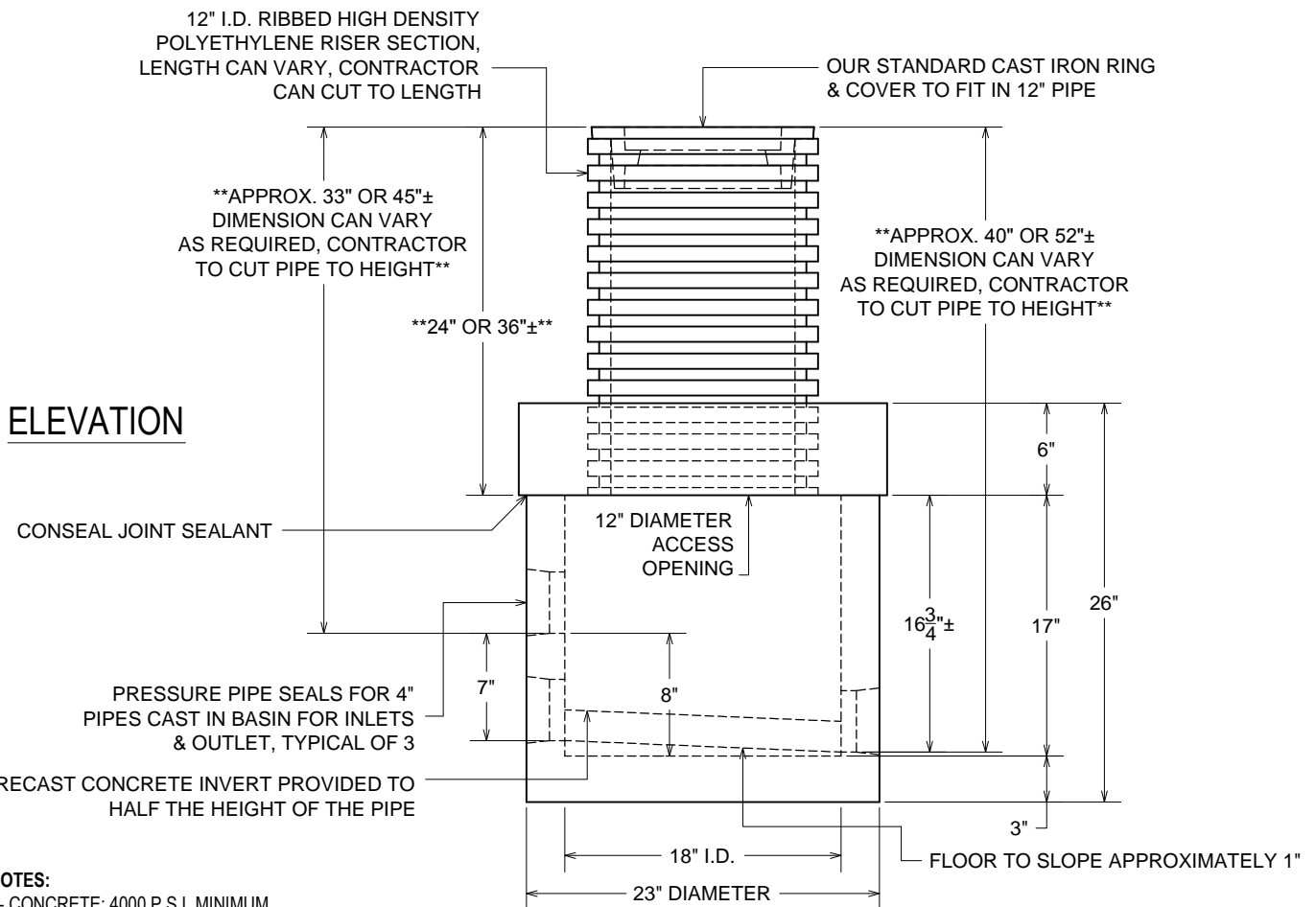

**NOTES:**

- CONCRETE: 4000 P.S.I. MINIMUM
- REINFORCING: GRADE 60 MINIMUM
- SUITABLE FOR AASHTO HS-20-44 LOADINGS WHEN PLACED ON PROPERLY PREPARED BASE & BACKFILLED TO CREATE A SOIL ENVELOPE AROUND HDPE PIPE & THE CONTRACTOR CASTS A 3'X3'X8" THICK CONCRETE COLLAR AROUND THE TOP OF THE SAMPLING BASIN

ACTUAL DIMENSIONS OF CONCRETE PRODUCTS MAY VARY SLIGHTLY



DRAWING NOT TO SCALE

SAMPLING BASIN.DWG  
DATE CREATED: 11/03  
UPDATED: 7/16

12650 Tucson Street • Henderson, Colorado 80640 • 303-659-3747, Fax 303-659-1333  
2671 South Greeley Hwy • Cheyenne, Wyoming 82007 • 307-634-0695, Fax 307-634-0694  
10021 Amarillo Blvd East • Amarillo, Texas 79108 • 806-374-3747, Fax 806-335-3717

[www.vaughnconcreteproducts.com](http://www.vaughnconcreteproducts.com)